



Zoning & Planning Committee Report

City of Newton In City Council

Thursday, August 13, 2020

Present: Councilors Crossley (Chair), Danberg, Albright, Baker, Ryan, Krintzman, Wright, and Leary

Also Present: Councilors Bowman, Humphrey, Noel, Kalis, Norton, Downs, Gentile, Greenberg, Malakie, Markiewicz, Lipof, and Kelley

Planning & Development Board: Peter Doeringer (Chair), Kevin McCormick, Kelley Brown, and Christopher Steele

City Staff: Barney Heath, Director of Planning and Development; Zachery LeMel, Chief of Long-Range Planning, Cat Kemmett, Associate Planner, Jonathan Yeo, Chief Operating Officer; Nathan Giacalone, Committee Clerk

#322-20 Appointment of Eliza Datta to the Community Preservation Committee
HER HONOR THE MAYOR appointing Eliza Datta, 40 Homer Street, Newton, as the Affordable Housing representative member of the COMMUNITY PRESERVATION COMMITTEE for a term to expire on July 31, 2022. Ms. Datta will complete Mr. Peter Sargent's term which ends on July 31, 2022. (60 days: 09/21/2020)

Action: **Zoning & Planning Approved 7-0-1 (Councilor Leary not voting)**

Notes: The Chair welcomed Ms. Datta to speak and introduce herself and talk about why she is interested in serving on the Community Preservation Committee (CPC). Ms. Datta said that she has 20 years of experience as an affordable housing developer, has advocated for affordable housing at the federal and state level, and has recently been involved more at the local level. She is also a member of the Newton Housing Partnership since it reformed in March 2019 and serves on its Zoning subcommittee.

The Committee thanked her for willingness to serve.

Committee Questions:

Q: Newton does not have many affordable housing developers proposing projects here. Why do you think this is?

A: Some of the challenges have to do with the costs and complex nature of getting projects approved in Newton. Reforming the zoning ordinances can be an effective way to introduce

greater housing diversity in Newton. CPC funds can be leveraged to construct more affordable housing Newton.

Councilor Albright moved approval which carried 7-0-1 (Councilor Leary not voting).

#287-20 Rezoning of Takings to Public Use

DIRECTOR OF PLANNING requesting change of zone to Public Use for portions of land located at 23 Parkview Avenue (currently MR1) acquired in 2016 for the expansion of Cabot School, and at 300 Hammond Pond Parkway, known as Webster Woods, (currently SR1) acquired in 2019 for open space use and conservation purposes.

Action: **Zoning & Planning Approved 8-0; Public Hearing Closed 08/13/2020**

Notes: The Chair summarized the purpose for acquiring and rezoning the two properties, as provided in the back up materials. 23 Parkview Avenue was obtained through eminent domain in 2016 to enable expansion of the Cabot Elementary School. 300 Hammond Pond Parkway (Webster Woods) was acquired through eminent domain in 2019 to preserve public access to this open space. For both properties, the rezoning is necessary to complete the process. For Webster Woods, the rezoning must precede a conservation restriction designation.

The Public Hearing was opened, and no member of the public wished to speak. The Zoning & Planning Committee voted 8-0 to close the Public Hearing.

Councilor Albright spoke about Daphne Potter, the resident who sold her house to allow the City to proceed with the Cabot School expansion. She conveyed the city's appreciation for Ms. Potter's gracious collaboration.

Councilor Albright moved approval which carried 8-0.

#88-20 Discussion and review relative to the draft Zoning Ordinance

DIRECTOR OF PLANNING requesting review, discussion, and direction relative to the draft Zoning Ordinance.

Action: **Zoning and Planning Held 8-0**

Notes: The Chair introduced the item and the Planning Department has provided its recommendations in support of the goals. The Committee must evaluate ideas within the proposal, understand impacts, and strive to reach consensus on policy decisions. She added that there will need to be a discussion about what it means to "protect the physical character of a place." Chief of Long-Range Planning Zachery LeMel delivered a presentation (copy attached). Mr. LeMel reviewed the zoning redesign process so far, the guiding goals and objectives moving forward, and recommendations to revise mechanisms and standards in service to those goals.

6 Month Recap:

Mr. LeMel noted that zoning redesign has been ongoing for several years. Since the beginning of this term, ZAP has devoted its Committee meetings to review of residential district zoning found within Article 3, and other relevant material found within Article 2 and 9.

Mr. LeMel further noted that since COVID isolation began, Zoom meetings have drawn an average of 16 Councilors to Zoom meetings, joined by at least 50 members of the public (a significant increase from in-person meetings). The Planning Department has also been holding bi-weekly public office hours over Zoom and has been holding regular focus groups with local architects and builders.

Goals:

Mr. LeMel reiterated that the Committee reaffirmed three primary goals of zoning redesign. The first is to facilitate an increase of housing opportunities in Newton. This goal can be accomplished, in part, by creating more of the “missing middle” housing options which can range from smaller scale detached single-family homes to mid-rise apartment buildings. Allowing a range of smaller housing types would accommodate people with a broader range of incomes. Another main goal is to promote environmental and economic sustainability. This will be done by incentivizing environmentally friendly housing features along with allowing greater density, particularly near village centers and public transit. Greater density will create more walkable neighborhoods and increase customers for local business at the same time. Zoning Redesign will also seek to preserve and protect what is currently working in Newton neighborhoods and to ensure that new development fits within the context of these communities.

Revised Mechanisms & Standards Recommendations:

Mr. LeMel said that the residential district dimensional standards are derived from the physical character already found within Newton. Dimensional standards for lots closer to village centers and transit stops would be smaller and allow greater coverage, while lots further away from these spots are larger and require greater setbacks. This will be to encourage different housing options on the smaller lots and overall there will be simpler regulations in place. Each building Type would be limited to a maximum footprint and number of stories based on typical existing building forms in a Newton district. Mr. LeMel explained how the data used to recommend these dimensional standards derives from the Pattern Book.

Mr. LeMel described changes to the proposed ordinance resulting from feedback since 2018. For example, allowable building footprints were modified to be more in line with existing median sizes by house type. The proposed maximum footprint of the House Type D was reduced from 3,500 square feet to 2,300 square feet to reflect the median for the equivalent house type as 2,314 square feet. Similarly, the proposed maximum duplex footprint has been reduced from 2,000 square feet to 1,800 square feet to be closer to the existing median of 1,671 square feet. For three-unit buildings and the small apartment house, the maximum footprint size was increased based on standards derived from Urban Design Best Practice and historical building forms.

Mr. LeMel also highlighted revisions to regulating the allowance two-units within traditionally single-family building forms to respect neighborhood character and increase housing opportunity.

The change recommends allowing up to two-units within new construction of House A, House B, and House D Building Types. The form of these Building Types derives directly from the form and pattern that already exists within Newton. These contextual rules will prevent the oversized boxy two-family homes that arise from teardowns often allowed by-right under the current ordinance.

The Small Shop building type is under review to see if it is worth keeping as a form to be promoted. These single-story retail spaces were often created for temporary purposes in times of depression or to hold property. The Planning Department asks the Committee to consider removing the Small Shop in favor of the Shop House. The Shop House is a multi-story building with retail on the first floor and either additional business or residential space on upper floors. This building design is a more efficient use of space in village centers.

Building components are another tool that can be used to add living space in a controlled, yet flexible, manner. Certain building components such as bay windows and side and rear additions would be allowed to extend beyond the maximum building footprint for the main building. Under certain conditions, these components could be added by-right. The intention is that by allowing for the easy expansion of existing property, teardowns used to build oversized homes would be disincentivized.

Garage standards are also being taken up within the context of zoning redesign. Form-based mechanisms will be used in order to minimize the visual impact of garages, increase public safety, and provide options for Newton's diverse housing stock. While flexible, these options will also be predictable and designed within the community context. The multiple varieties of garages within Newton, which include front facing, side facing, and rear detached are the foundation for the recommended standards within the draft ordinance. One of the design standards are that front facing garages must have a separate garage door for each bay of a multi-car garage in order to reduce the sense of scale.

The proposed ordinance would promote multi-unit conversions as an incentive to preservation of existing structures (House Types A, B, and D only) and increase housing options at the same time. Conversions of up to 6 residential units would be allowed by-right, though lot and building size, as well as building configuration and health and safety codes, would limit how many units are feasible. Currently, only about 8 percent of single-family homes in Newton meet the minimum required size for a 6-unit conversion. Parking requirements reduce this opportunity as well.

These recommended initiatives are tools used to promote "Gentle Density" - the practice of diversifying the housing stock within existing built forms to remain in scale with an area and make

more efficient use of land where it is expensive. As Mr. LeMel showed with multiple examples, multi-unit conversions blend into the neighborhood when done right.

The courtyard cluster is also being explored as an option to allow increased housing density close to public transit. These would only be allowed in R4 and N districts. Adaptive reuse is another tool under consideration which will allow controlled evolution within neighborhoods through a more flexible policy towards home businesses. Discussions on this are not settled but are considering street type as the factor to determine eligibility. Parking requirements continue to be discussed, and the current proposal will need to address whether minimum parking requirements should be approved or a more flexible approach that allows greater developer judgement at each site.

Mr. LeMel concluded his presentation and several Councilors thanked him for his efforts in the zoning redesign process.

Discussion:

The Chair clarified that it is intended that the Committee will not vote to recommend any of the zoning redesign proposals separately to the full Council. It is intended that the entire draft ordinance (Chapter 30) will be voted in Committee by Fall of 2021 and by the full Council by the end of the term, December 2021. Straw votes will be taken in Committee on certain articles to gauge consensus along the way. Public hearings will also be held for each substantive section of the ordinance after the Committee has reached reasonable consensus on what to propose.

Councilors agreed on the need to establish consensus on the proposed ordinance so that a final vote would aim for more than a narrow approval, stating that with such a contentious issue, anything less would be an error. Some said that this approach would facilitate agreement on the issues still in contention. Councilors also spoke on the importance of being clear over goals voted on in committee by straw vote.

C: A Councilor said that multi-unit conversions and two-unit by-right constructions are two concerning proposals and allowing by-right anywhere is not a good idea as it will lead to more teardowns. Reduction in street frontage will also create more opportunities for lot division. Elimination/reduction of the parking requirement is also a bad idea as it will put more cars on the streets. The Planning Department should provide a comparison with the current ordinance in addition to the drafts it has already provided to ZAP. The proposed ordinance will change more in Newton beyond only density.

C: A Councilor said that as Mr. LeMel said in his presentation, public participation has been excellent over Zoom. The Committee needs to be open to all feedback and clarify that, contrary to some concerns, opposing zoning redesign is not racist. The Committee also needs to address the fears received in many letters about how zoning redesign will impact the city and the misinformation which has generated these fears. Architects have also spoken up to say that they feel their feedback on the proposed ordinance is not being considered. Rather than affordable

housing, a more accurate term to use would be attainable housing to allow middle income families as well and opportunities to return to Newton.

C: Regarding zoning redesign, it is often asked “what is wrong with Newton as is?” Newton faces both a housing and a climate crisis and can do more to address each of these. Staying the course will only make things worse for Newton in the long-term.

C: The building professionals focus group should include a wider spectrum of builders and not only those who build high-end developments. The main goal should not be to protect the values of single-family homes but to promote a wider range of housing options to allow more income groups to move into Newton. The housing crisis is not local but regional. It may be a good idea to remove onsite parking minimums in village centers and lots near transit centers, but the Committee needs to discuss more the question of removing them across the entire city more. It is also important that the discourse over zoning redesign continue to be respectful and constructive.

C: The proposed zoning code should respect the existing character of Newton and be flexible enough to meet the needs of modern families. House conversions are one example of this as multigenerational families were larger on average in the past, leading to the large size of many older (turn of the century) homes. Now that families tend to be smaller, the proposed ordinance should allow for the easy conversion of these homes into multi-family. By extension, the code should allow for the easy construction of accessory dwelling units to facilitate aging in place for seniors and to promote gentle density.

The proposed ordinance should also incentivize future families to own fewer cars.

Q: The courtyard cluster photo had different sized structures; is this allowed in the current proposal?

A: The courtyard cluster proposal allows for multiple house types in a single development. Parking requirements would only be eliminated for construction of two units or less and the developer can still build the parking if they wish.

C: The proposed ordinance needs to be targeted to ensure that it meets its goal of promoting more middle market housing to accommodate a wider range of incomes. The desire to protect Newton’s 13 villages’ character must be respected, but zoning redesign also needs to be bold in order to meet community housing needs. This means incentivizing train travel and capping the size of new units. Newton is already good at building large Riverside-style housing developments with some affordable units, but it needs to do more to build the “missing middle.”

C: It is important to accommodate a wider range of incomes as home ownership is one of the best ways for families to build generational wealth and to promote economic growth that benefits the whole community.

C: Zoning redesign should be more visible and accessible on the city website to aid public participation. Raising taxes will not make Newton more affordable and the city needs to make sure it develops public space to accommodate the increased housing density. The allowed sizes of courtyard cluster houses should also be clarified.

A: Director Heath noted that it can be challenging to be placed on the website front page currently as elections and COVID-19 information take priority. The Planning Department continues working to make zoning redesign accessible and user friendly. The Mayor's Newsletter and listserv already reaches about 27,000 residents and will begin to communicate on zoning redesign efforts.

C: Historically cities have improved after crises and Newton can do the same after COVID-19. Residents have understandable concerns about quality of life in Newton that zoning redesign should address such as public green spaces. Wildlife should also be considered in the proposed ordinance with features like wildlife corridors and habitat. Incentivizing lawns to consist of more natural plants could help imperiled pollinators and reduce the need for powered lawn equipment.

C: Newton already has a diverse housing stock despite what some letters being received suggest and the draft ordinance should use this existing strength. It seems that the real overarching concerns is the teardowns which lead to unaffordable non-contextual homes.

C: The draft ordinance will need to be carefully examined for loopholes. While it must be flexible enough to meet concerns such as aging-in-place, it needs as well to avoid massive apartment buildings and incentivize walkable neighborhoods. Smaller units are the key for this approach.

C: The amount of data and research behind the proposed ordinance is impressive. As decisions are being made about the boundary lines on maps, the data behind these decisions should be presented. This should be accompanied by data of the complete distribution of house sizes in Newton by percentile average and median. Newton should continue studying how comparable communities have undertaken zoning redesign efforts. It is also good to use the term attainable housing rather than affordable.

C: The Committee should consider how village commercial centers can accommodate middle-range housing before expanding into residential neighborhoods. The current approach of laborious review of each article of the draft ordinance is correct because none of them exist in a vacuum. Revising future articles may require a revisit of prior articles. It must also be said that while straw votes are non-binding, they are important markers of the Committee's consensus. The draft ordinance should also balance concerns for student housing and measures to curtail speculative housing.

C: Many of the zoning redesign questions received so far are being incorporated into the "decision tree" document provided by Mr. LeMel. The Committee is only at the beginning of its discussions on Article 3 and still has many details to review, and these talks will use the decision

tree as a guide. Since the decision tree will continue to be updated, Councilors are encouraged to submit as much feedback as possible to help the process. The interaction between university housing and the missing middle should also be analyzed.

C: It is the Chair's intention to ask the councilors and Planning Board members to continue to provide feedback to the information presented by Mr. LeMel. She said that if anybody has questions on or wants to propose modifications to the draft to send those to the Clerk/Planning Department. The Committee has more deliberative work to do before a product can be released for a public hearing.

Q: Are there changes coming to the R1, R2, R3, and R4 classifications in the draft ordinance maps?

A: Planning is currently working on revisions and is looking at the different options of what the maps can achieve, with multiple opportunities for public feedback. These questions will begin to look at what house types better fit into different classifications. The upcoming straw vote will not include a map as the Committee process is reviewing each section individually and will not get to a map until mixed-use districts have also been reviewed.

Q: Are updated maps supposed to be coming out by middle to end of August?

A: Using this meeting as a guide, the next meeting will likely be a working meeting to review questions that have arisen from review of the draft. It is not the time to release new draft maps.

C: While it may not be time to release new maps, it would be helpful to remind residents of the general sense of where they will be located. If possible, it would also be helpful to receive a comparison table contrasting the proposed ordinance with the existing one. This is needed to show what the city is receiving in exchange for what it is giving up by adopting the proposed ordinance. Some of these changes create new opportunities for development that need to be clearly understood.

C: The comparison table has been discussed in Planning staff meetings. Under the current ordinances adopted in 2015, there is a reference table that compares previous and current ordinance material. This could serve as a model for the closest thing to a direct comparison. As the Committee continues its review of the draft ordinance, someone from the Current Planning team will be available to speak on the current rules.

C: There are concerns that despite the high Zoom attendance, too many residents are preoccupied with the pandemic and unable to devote enough time to fully studying zoning redesign. How can the Council alleviate these fears and anxieties?

A: As has been said prior in the meeting, it needs to be restated that no formal vote is being taken on the proposed ordinance until December 2021. This has not been a rushed process as some have said, but the latest iteration of a process ongoing for about a decade. The Mayor's Office is planning to release a "Long Story" about zoning redesign to the 27,000 people on the city email list. The Committee hopes for in-person meetings to resume before the end of the term.

C: It is important to continue to develop a community engagement strategy in the era of COVID-19. The Committee will have to be creative with new ways to reach people.

Councilor Danberg moved hold which carried 8-0.

#323-20 Reappointment of Jeffrey Zabel to the Conservation Commission

HER HONOR THE MAYOR reappointing Jeffrey Zabel, 54 Oak Avenue, West Newton, as a regular member of the CONSERVATION COMMISSION for a term to expire on May 31, 2023. (60 days: 09/21/2020)

Action: Zoning & Planning Approved 8-0

Notes: The Committee reviewed the Mayor's reappointment of Jeffrey Zabel to the Conservation Commission for a term to end on May 31, 2023. Committee members expressed no concerns relative to the reappointment and voted unanimously in favor of approval with a motion from Councilor Krintzman.

#324-20 Reappointment of Susan Lunin to the Conservation Commission

HER HONOR THE MAYOR reappointing Susan Lunin, 22 Shaw Street, Newton, as a regular member of the CONSERVATION COMMISSION for a term to expire on May 31, 2023. (60 days: 09/21/2020)

Action: Zoning & Planning Approved 8-0

Notes: The Committee reviewed the Mayor's reappointment of Susan Lunin to the Conservation Commission for a term to end on May 31, 2023. Committee members expressed no concerns relative to the reappointment and voted unanimously in favor of approval with a motion from Councilor Krintzman.

#325-20 Reappointment of Kathryn Cade to the Conservation Commission

HER HONOR THE MAYOR reappointing Kathryn Cade, 195 Islington Road, Auburndale, as a regular member of the CONSERVATION COMMISSION for a term to expire on July 31, 2023. (60 days: 09/21/2020)

Action: Zoning & Planning Approved 8-0

Notes: The Committee reviewed the Mayor's reappointment of Kathryn Cade to the Conservation Commission for a term to end on July 31, 2023. Committee members expressed no concerns relative to the reappointment and voted unanimously in favor of approval with a motion from Councilor Krintzman.

#326-20 Reappointment of Judith Hepburn to the Conservation Commission

HER HONOR THE MAYOR reappointing Judith Hepburn, 132 Stanley Road, Waban, as a regular member of the CONSERVATION COMMISSION for a term to expire on May 31, 2023. (60 days: 09/21/2020)

Action: Zoning & Planning Approved 8-0

Notes: The Committee reviews the Mayor’s reappointment of Judith Hepburn to the Conservation Commission for a term to end on May 31, 2023. Committee members expressed no concerns relative to the reappointment and voted unanimously in favor of approval with a motion from Councilor Krintzman.

#327-20 Reappointment of Ellen Katz to the Conservation Commission

HER HONOR THE MAYOR reappointing Ellen Katz, 31 Williams Street, Newton Upper Falls, as a regular member of the CONSERVATION COMMISSION for a term to expire on May 31, 2023. (60 days: 09/21/2020)

Action: Zoning & Planning Approved 8-0

Notes: The Committee reviews the Mayor’s reappointment of Ellen Katz to the Conservation Commission for a term to end on May 31, 2023. Committee members expressed no concerns relative to the reappointment and voted unanimously in favor of approval with a motion from Councilor Krintzman.

Referred to Zoning & Planning and Public Safety Committees

#301-20 Request for a discussion on the impact of outdoor fuel burning

COUNCILORS KELLEY, CROSSLEY, LEARY, NORTON, WRIGHT, MALAKIE, DOWNS, AND BOWMAN requesting a discussion with the Planning Department, Fire Department, and Sustainability Team on the impacts of fuel-burning outdoor fireplaces, chimneys, fire pits, pizza ovens, etc., including setback and maximum lot coverage requirements, air quality/pollution, and fire protection in relation to permitting, zoning enforcement, fire code, and Newton’s Climate Action Plan.

Action: Zoning & Planning No Action Necessary 8-0

Notes: Chair Crossley explained that the No Action Necessary vote is requested as a reviewed docket item was accepted on the docket to clarify its scope.

Councilor Krintzman moved No Action Necessary which carried 8-0.

The meeting adjourned at 9:59 pm.

Respectfully Submitted,

Deborah J. Crossley, Chair



Revisions and Updates to Residence Districts

Article 3 – Residence Districts

08.13.20 – ZAP Committee

Agenda

- **Part I: 6-Month Recap**
- **Part II: Guiding Goals & Objectives**
- **Part III: Recommendations to Revise Mechanisms & Standards**
- **Part IV: Looking Ahead**

Part I: 6-Month Recap

ZAP

- **Article-by-Article review process (February)**
 - **Workshops**
 - **Summary/Editing**
 - **Public Hearing/Straw Vote**
- **No final vote until fall 2021**

ZAP

- **Residence Districts (March)**
 - **7 Workshops**
 - **2 Presentation from local architects and building professionals**

ZAP

- **Attendance**
 - **Averaged 16 City Councilors**
 - **Majority of Planning & Development Board**
 - **Greater public attendance since moving to Zoom**

Engagement & Outreach

- **7 Bi-Weekly Public Office Hours (April)**
- **4 Architect and Building Professional Focus Groups**
- **Updated Website**



Part II: Guiding Goals & Objectives

Goals

- Facilitate an increase and diversity of housing opportunities citywide



Goals

- Promote economic and environmental sustainability



Goals

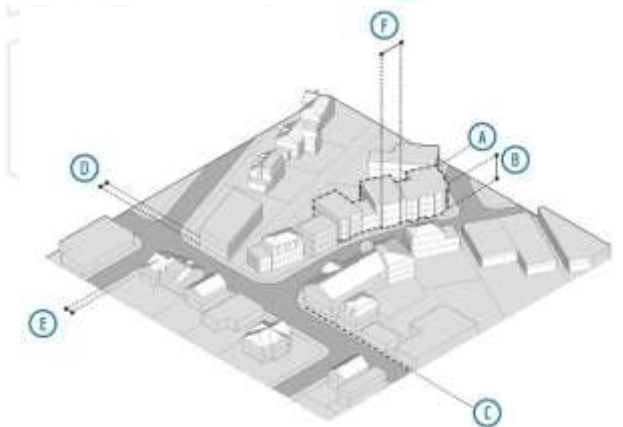
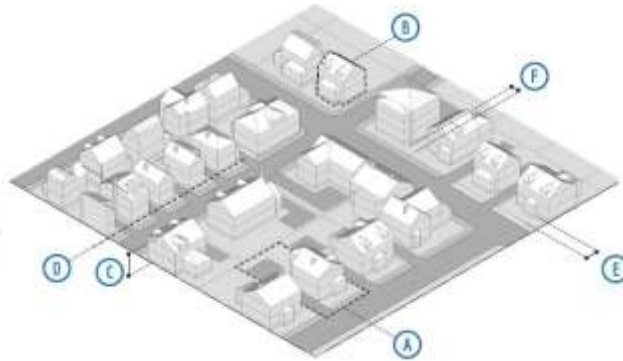
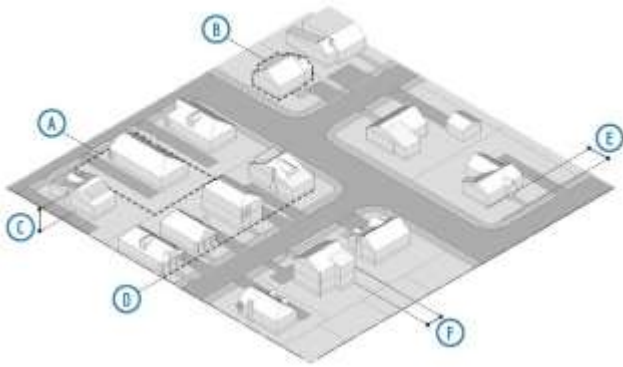

- **Preserve and protect what we like in our neighborhoods**
- **Encourage new development to fit in the context of our neighborhoods and villages**



Part III: Revised Mechanisms & Standards Recommendations

Dimensional Standards & Building Types

- **Match district dimensional standards and allowed building types with:**
 - **Existing development patterns (R1, R2, and R3)**
 - **Facilitate desired patterns near transit and village centers (R4 and N)**

Dimensional Standards & Building Types

Larger Lots - further from village centers/public transit

Smaller lots- closer to village centers/public transit

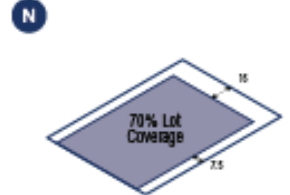
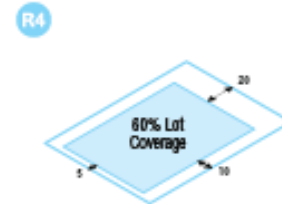
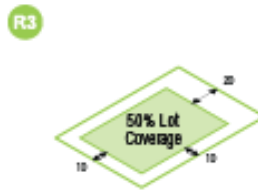
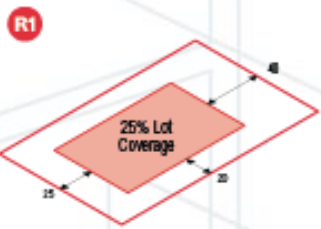

Building Types - Dimensional Standards

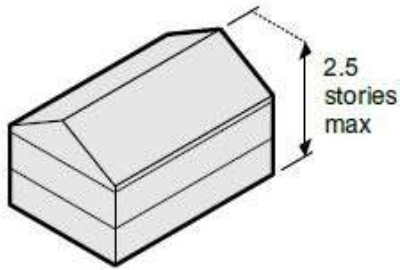

House A

max footprint 2400 sf

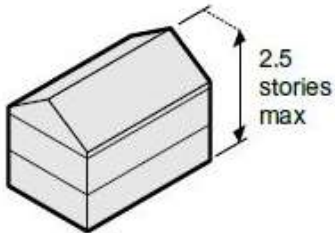

House B

max footprint 1400 sf

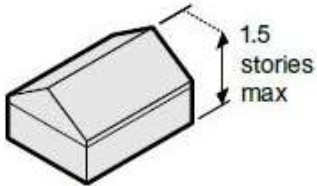

House C

max footprint 1200 sf

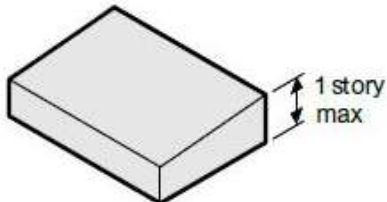

House D

max footprint 2300 sf

- **Simpler regulations**
 - **Acknowledge Newton's diversity by removing building width and depth requirements**

Building Types - Dimensional Standards

House A to Duplex derived from Existing Conditions

House Type	Previous Footprint (max.)	Proposed Footprint (max.)	Existing Conditions (Median)
A	2,400 sf	2,400 sf	2,407 sf
B	1,400 sf	1,400 sf	1,373 sf
C	1,200 sf	1,200 sf	1,351 sf
D	3,500 sf	2,300 sf	2,314 sf
Duplex	2,000 sf	1,800 sf	1,671 sf

Building Types - Dimensional Standards

Triple Decker to Small Multi-Use Building derived from Urban Design Best Practice

House Type	Previous Footprint (max.)	Proposed Footprint (max.)
Triple Decker (3-Unit Building)	1,600 sf	1,800 sf
Townhouse Section*	1,500 sf	1,500 sf
Small Apartment House (4-8 Unit Building)	2,500 sf	3,600 sf
Small Multi-Use Building*	12,000 sf	12,000 sf

* Building Types with a maximum building width

Building Types - Dimensional Standards

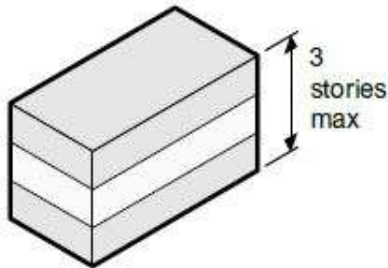

Triple Decker
max footprint 1800 sf

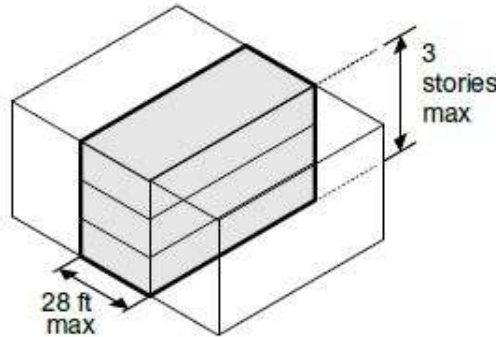

Townhouse Section
max footprint 1500 sf

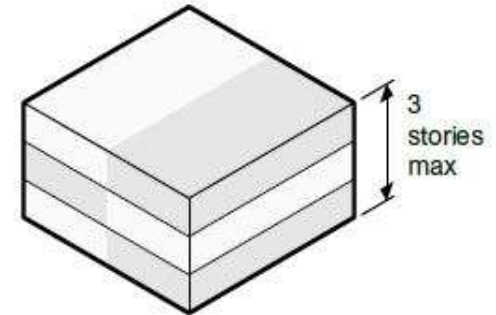

Small Apartment House
max footprint 3600 sf

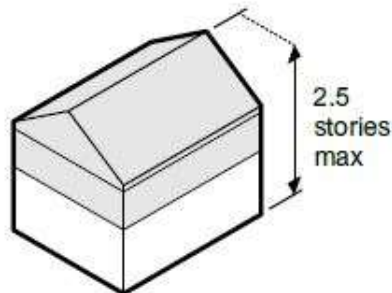

Shop House
max footprint 2000 sf

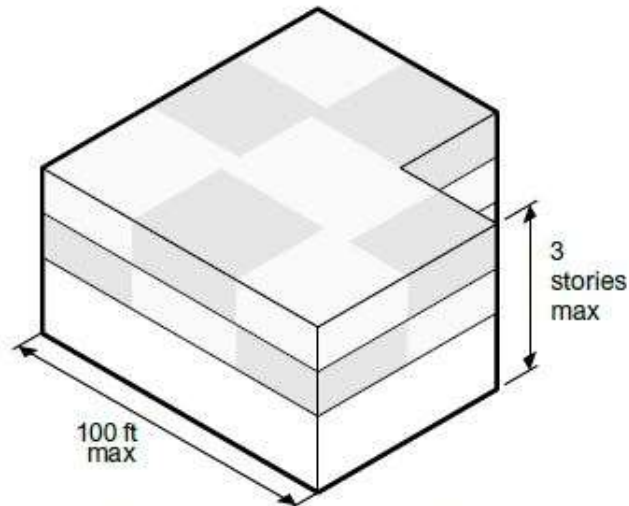

Small Multi-Use Building
max footprint 12000 sf

Building Types - House A, House B, and House D Allow Two Units By-Right



- **Allow two-units within new construction**
- **A form and pattern that has exists throughout Newton**

Building Types - House A, House B, and House D Allow Two Units By-Right



- **Two family homes being built under the current code**



Building Types - Small Shop

- **Propose to remove Small Shop building type**



- **Existing form, but do we want to encourage new?**
- **The Shop House allows ground floor commercial with residential and office above**

Building Types - Small Shop



VS.

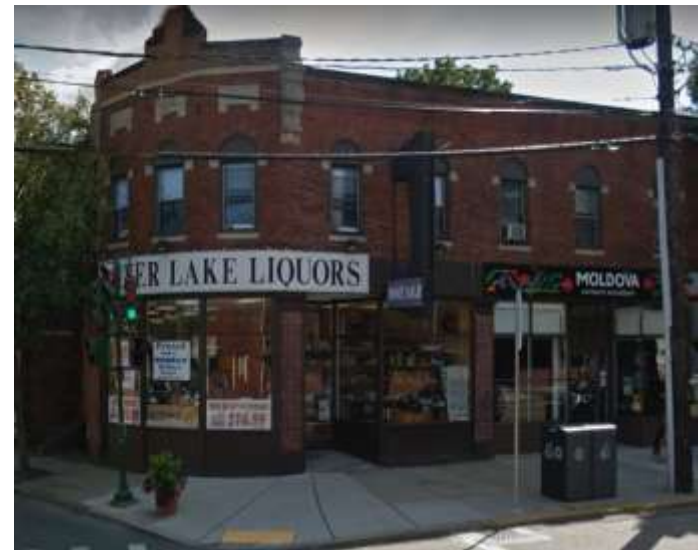

Building Components



Side Wing

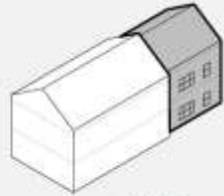

Rear Addition

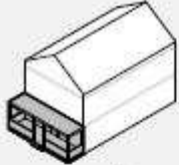

Porch

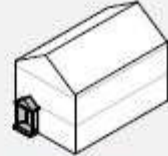

Projecting Entry



Bay

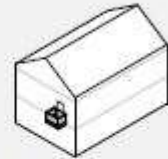

Balcony

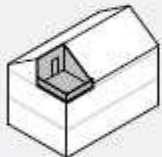

Roof Deck

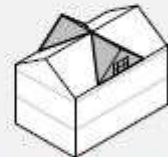

Cross Gable



Dormer

- **25% increase allowed in House A through Duplex**
- **10% increase allowed in Triple Decker through Small Multi-Use Building**

Building Components

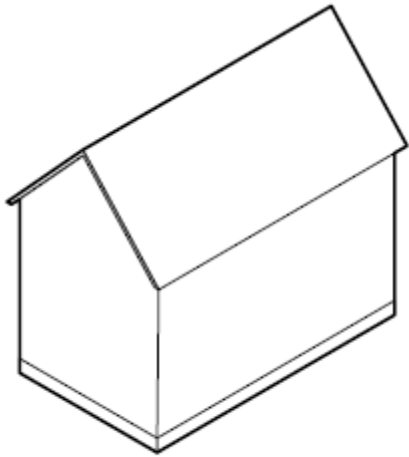

MAIN MASSING of a BUILDING

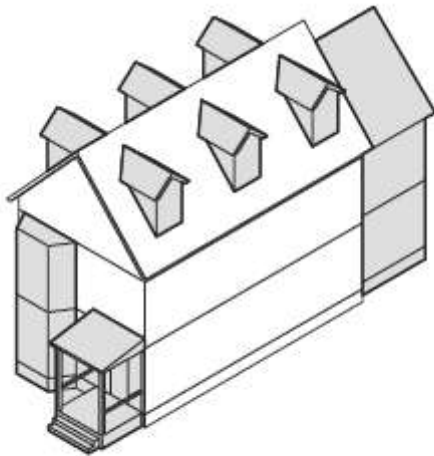

Additional BUILDING COMPONENTS

- **Replace Special Permit request to increase square footage**
- **Allowance tied to Newton's existing conditions**
- **By-right (within limits)**
- **De Minimus 2.0**

Building Components

Component Allowance Derived from Existing Character

Building Type	Existing Conditions in Newton		Zoning Code Proposal		
	Existing Footprint (median)*	Percentile of Existing Building Type Footprints	Recommended Footprint per Code (maximum)	25% Increase through Building Components	Building Footprint + Components (maximum)
A	2,407 sf	2,998 sf (80 th)	2,400 sf	600 sf	3,000 sf
B	1,373 sf	1,723 sf (80 th)	1,400 sf	350 sf	1,750 sf
C	1,351 sf	1,581 sf (75 th)	1,200 sf	300 sf	1,500 sf
D	2,314 sf	2,822 sf (80 th)	2,300 sf	575 sf	2,875 sf
Duplex	1,871 sf	2,282 sf (90 th)	1,800 sf	450 sf	2,250 sf

Garage Design Standards

- **Utilize form-based mechanisms to:**
 - **Minimize visual impact/dominance**
 - **Increase public safety**
 - **Provide options for Newton's diverse home and lot configurations**

Garage Design Standards



Front Facing



Rear - Detached



Side Facing - Front



Side Facing - Side

Multi-Unit Conversions

- **Only allowed for existing House A, B, and D (incentive for preservation)**
 - **Limited exterior alterations allowed**
- **Typical existing eligible buildings in Newton can accommodate 3-4 units based on size**
- **Allow conversions of up to 6-units by-right**

Where can a 6-unit Conversion Occur?

- Only 8% of existing single-family homes in Newton meet the required size
 - Parking requirements reduce this

% of Houses by-Ward above 7,200 sf

House Type	Ward One	Ward Two	Ward Three	Ward Four	Ward Five	Ward Six	Ward Seven	Ward Eight
A, B, and D	0.33%	0.98%	1.23%	0.34%	1.2%	0.53%	2.15%	1.38%

Multi-Unit Conversions



Two Family



6-Units

10/26/2017 10:30



Three Family



Two Family

**Brookings Institute –
“Gentle density can save our neighborhoods”**

- **Where land is expensive, allowing more homes per lot can increase affordability**
- **Diversifying the housing stock in resourced neighborhoods creates better access to economic opportunity**

Courtyard Cluster

- **Only allowed in R4 and N Districts**
 - **Areas close to public transit and village centers**



Adaptive Reuse



- **Allows controlled evolution within neighborhoods**
- **Allows some uses we already allow in residential districts (ex. museums and daycare centers)**
- **Allows reuse for some broader use categories**

Adaptive Reuse

- **Could we allow certain Adaptive Reuse by-right along certain street types?**

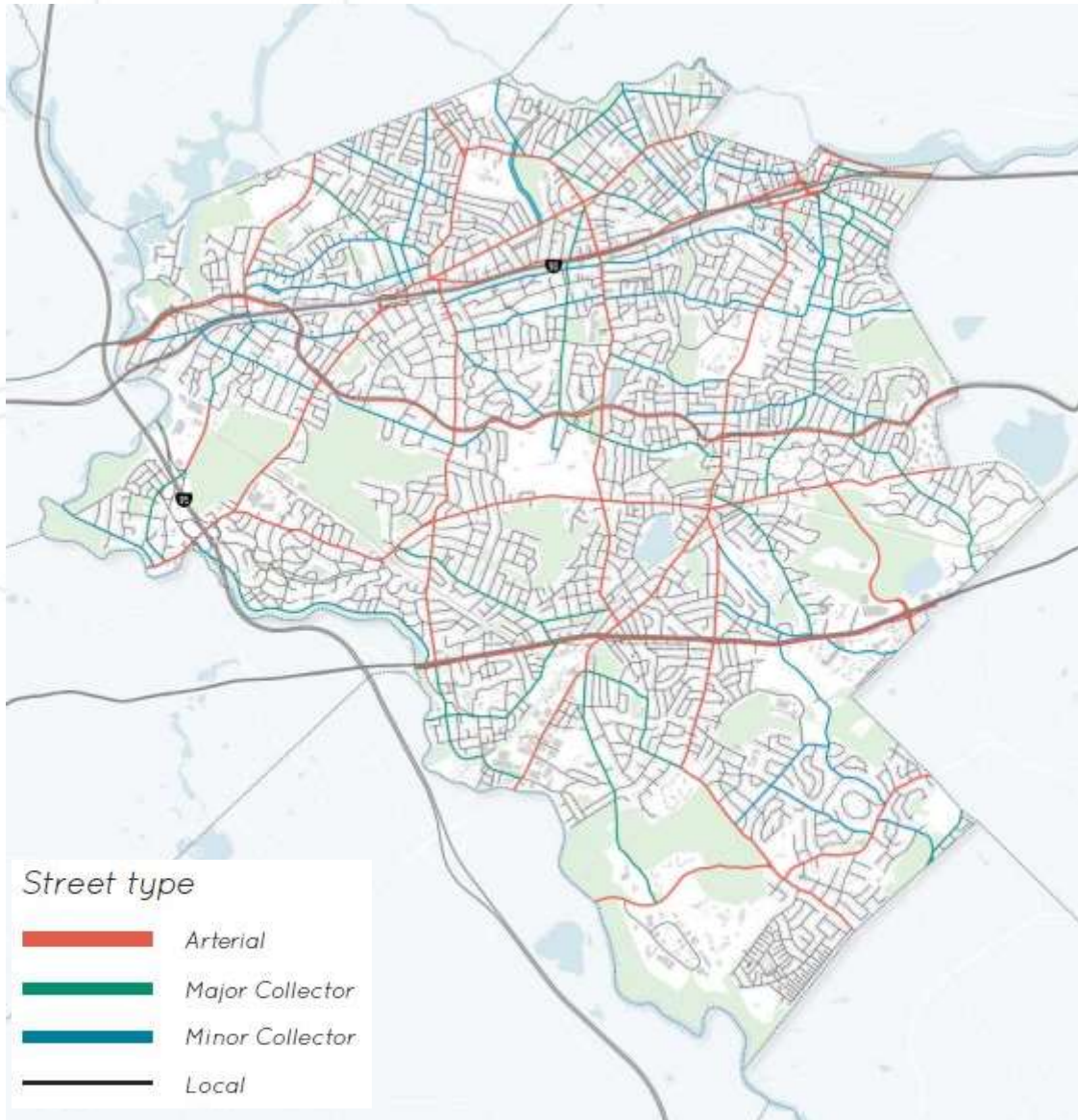

Parking Requirements



Reduce \$\$

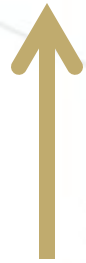

Development
Diversity

- **Eliminate requirements for single- and two-family homes**
- **On-street parking counts for non-residential uses**
- **Introduce parking maximums**

Part IV: Looking Ahead

Looking Ahead

Continued discussion on the revisions and further editing to the draft text

Discussion of the Residence Districts Zoning Map

Upcoming Meetings

8/19 – Office Hours

8/31 – ZAP Meeting

Discussion

Thank You!

